



Precision Split

Owner/Operator Manual
Manuel Du Propriétaire/Utilisateur
Manual del propietario/operador

Model
917001 – 27-Ton Log Splitter



- GB** ENGLISH
- F** FRANÇAIS
- E** ESPAÑOL



03860300B 4/09
Printed in USA

TABLE OF CONTENTS

SAFETY	4	TROUBLESHOOTING	19
ASSEMBLY	7	SERVICE PARTS	20
CONTROLS AND FEATURES	10	ACCESSORIES	20
OPERATION	11	SPECIFICATIONS	20
MAINTENANCE SCHEDULE	16	WARRANTY	21
STORAGE	18		

INTRODUCTION

NON-ENGLISH MANUALS



Manuals in languages other than English may be obtained from your Dealer. Visit your dealer or www.ariens.com for a list of languages available for your equipment.

Manuals printed in languages other than English are also available as a free download on our web site:

<http://www.ariens.com>

Manuales en idiomas diferentes del inglés



Puede obtener manuales en idiomas diferentes del inglés en su distribuidor. Visite a su distribuidor o vaya a www.ariens.com para obtener una lista de idiomas disponibles para su equipo.

También puede imprimir manuales en idiomas diferentes del inglés descargándolos gratuitamente de nuestra página Web:

<http://www.ariens.com>

Manuels non anglais



Des manuels dans différentes langues sont disponibles chez votre revendeur. Rendez-vous le site www.ariens.com pour consulter la liste des langues disponibles pour votre équipement.

Les manuels imprimés dans des langues différentes de l'anglais sont également disponibles en téléchargement gratuit sur notre site Web :

<http://www.ariens.com>

THE MANUAL

Before operation of unit, carefully and completely read your manual. The contents will provide you with an understanding of safety instructions and controls during normal operation and maintenance.

MODEL AND SERIAL NUMBERS

When ordering replacement parts or making service inquiries, know the Model and Serial numbers of your unit.

Numbers are located on the product registration form in the unit literature package. They are printed on a serial number label, located on the frame of your unit near the engine (figure 1).

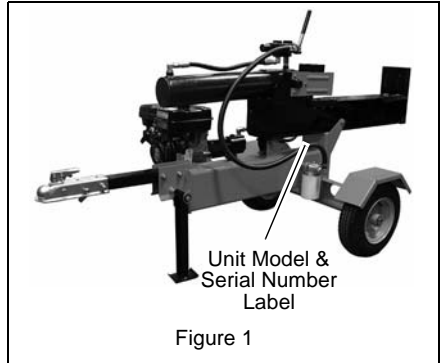

Figure 1

- Record Unit Model and Serial numbers here.

- Record Engine Model and Serial numbers here.

PRODUCT REGISTRATION

The Ariens dealer must register the product at the time of purchase. Registering the product will help the company process warranty claims or contact you with the latest service information. All claims meeting requirements during the limited warranty period will be honored, whether or not the product registration card is returned. Keep a proof of purchase if you do not register your unit.

Customer Note: If the Dealer does not register your product, please fill out, sign and return the product registration card to Ariens or go to www.ariens.com on the Internet

UNAUTHORIZED REPLACEMENT PARTS

Use only Ariens replacement parts. The replacement of any part on this unit with anything other than an Ariens authorized replacement part may adversely affect the performance, durability, and safety of this unit and may void the warranty. Ariens disclaims liability for any claims or damages, whether warranty, property damage, personal injury or death arising out of the use of unauthorized replacement parts.

NOTE: A complete Parts manual may be downloaded from www.ariens.com on the Internet

DELIVERY

Customer Note: If you have purchased this product without complete assembly and instruction by your retailer, it is your responsibility to:

- Read and understand all assembly instructions in this manual. If you do not understand or have difficulty following the instructions, contact your nearest Ariens Dealer for assistance.

NOTE: To locate your nearest Ariens Dealer, go to www.ariens.com on the Internet.



WARNING: Improper assembly or adjustments can cause serious injury.

Before Attempting to Operate Your Unit:

1. Make sure all assembly has been properly completed.
2. Understand all Safety Precautions provided in the manuals.

3. Review control functions and operation of the unit. Do not operate the unit unless all controls function as described in this manual.
4. Review recommended lubrication, maintenance and adjustments.
5. Review Limited Warranty Policy.
6. Fill out a product registration card and return the card to the Ariens Company or go to www.ariens.com.

DISCLAIMER

Ariens reserves the right to discontinue, change, and improve its products at any time without notice or obligation to the purchaser.

The descriptions and specifications contained in this manual were in effect at printing. Equipment described within this manual may be optional. Some illustrations may not be applicable to your unit.

SAFETY



WARNING: This splitting machine is capable of crushing or amputating body parts. Failure to observe the safety instructions in the manuals and on decals could result in serious injury or death. Tragic accidents can occur if the operator is not alert to the presence of children. Never assume that children will remain where you last saw them. Stop engine and allow moving parts to stop before leaving operator's position.

SAFETY ALERTS



Look for these symbols to point out important safety precautions. They mean:

- Attention!
- Personal Safety Is Involved!
- Become Alert!
- Obey The Message!



The safety alert symbol is used in decals and with this manual. Understand the safety message. It contains important information about personal safety.



DANGER: IMMINENTLY HAZARDOUS SITUATION! If not avoided, WILL RESULT in death or serious injury.



WARNING: POTENTIALLY HAZARDOUS SITUATION! If not avoided, COULD RESULT in death or serious injury.



CAUTION: POTENTIALLY HAZARDOUS SITUATION! If not avoided, MAY RESULT in minor or moderate injury. It may also be used to alert against unsafe practices.

NOTATIONS

NOTE: General reference information for proper operation and maintenance practices.

IMPORTANT: Specific procedures or information required to prevent damage to unit or attachment.

SAFETY DECALS AND LOCATIONS

ALWAYS replace missing or damaged Safety Decals. Refer to figure 2 for Safety Decal locations.

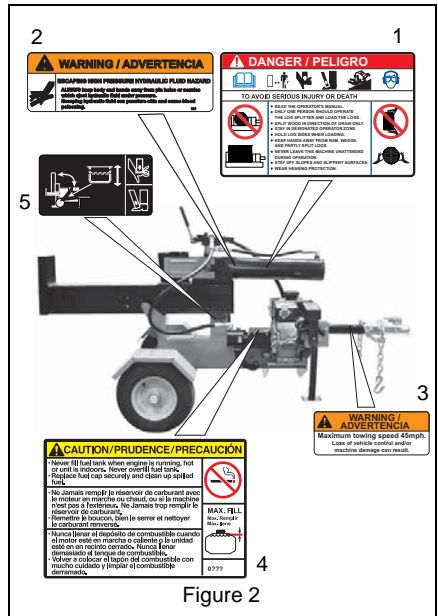

Figure 2

1. DANGER!



OL1801

Read the operator's manual.



OL1816

Keep children and others away from unit while operating. Only one person should operate the log splitter and load the logs.



Keep hands away from moving parts. Moving parts can crush or cut.



Operate the log splitter on level surfaces. Stay off slopes and slippery surfaces.



Always wear eye and hearing protection.



Hold logs on sides when loading. Keep hands and feet away from cylinder, wedge, and partially split logs.



Never place hands or any part of the body between a log and any part of the log splitter.



Do not split logs against the grain.



Split logs end to end in the direction of the grain only.

2. WARNING!



To prevent serious injury or death from escaping hydraulic fluid:

- ALWAYS keep body and hands away from pin holes or nozzles which eject hydraulic fluid under pressure.
- Escaping hydraulic fluid can puncture skin and cause blood poisoning.

3. WARNING!



Maximum towing speed of 45 mph (72.4 kph)

4. WARNING!



No smoking, No sparks, No flames.

Never fill fuel tank when engine is running, hot or unit is indoors. Never overfill fuel tank.

Replace fuel cap securely and clean up spilled fuel.



5. DANGER!



Keep hands away from moving parts. Moving parts can crush or cut.



OPERATOR ZONE

This unit is designed to be operated by one person located in the operator zone (see figure 3).

Horizontal Operating Position

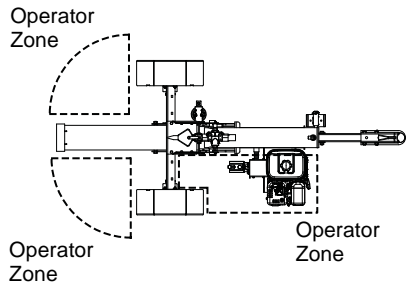

Vertical Operating Position

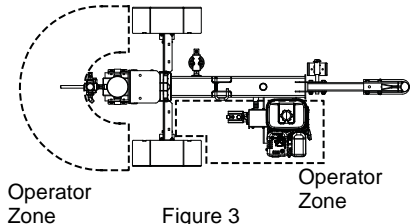

Figure 3

SAFETY RULES

If unit is to be used by someone other than original purchaser; loaned, rented or sold, ALWAYS provide this manual and any needed safety training before operation.

Only the user can prevent and is responsible for accidents or injuries occurring to themselves, other people or property.

Read, understand, and follow all instructions in the manual and on the machine before starting.

Understand:

- How to operate all controls
- The functions of all controls
- How to STOP in an Emergency

ALWAYS remove spark plug wire from spark plug before inspecting or working on this unit.

Inspect unit before each use for: missing or damaged decals and shields. Replace or repair as needed.

Before starting engine ensure that control lever is in neutral position.

Keep children, people, and pets away. Be alert and shut off unit if anyone enters work area. Keep children under watchful care of a responsible adult.

NEVER allow children to operate or play on or near unit.

Keep operator zone clear of all split logs and debris.

Operate unit only when there is sufficient light to clearly see work area.

Only trained adults may operate unit. Training includes being familiar with controls and actual operation.

Many accidents occur when more than one person operates the log splitter. If a helper is assisting in loading logs to be split, never operate the controls until the helper is clear of the area.

NEVER operate unit after or during the use of medication, drugs or alcohol.

NEVER allow anyone to operate this unit when their alertness or coordination is impaired.

Wear adequate safety shoes and protective gloves.

DO NOT wear loose clothing or jewelry and tie back hair that may get caught in moving parts.

Protect eyes, face and head from objects that may be thrown from unit. Wear appropriate hearing protection. Always wear safety goggles or safety glasses with side shields when operating.

ALWAYS keep hands away from all moving parts during operation. Moving parts can cut or crush body parts.

ALWAYS keep hands away from all pinch points.

Operate unit only when standing in operator zone. Unit stabilizers must be extended before starting unit.

DO NOT touch unit parts which might be hot from operation. Allow parts to cool before attempting to maintain, adjust or service.

ALWAYS stop unit and allow moving parts to stop before leaving operator zone. Do not leave running unit unattended.

DO NOT operate in the rain or in wet or damp locations. Assure that operator zone is free or debris and provides good footing.

Know the weight of logs. Limit logs to those you can safely control and the unit can safely handle.

Do not use log splitter for any purpose other than splitting logs.

Do not move the unit up or down a hill by hand. Use a tow vehicle with suitable braking system.

Use extra care when towing unit. DO NOT exceed 45 mph (72.4 kph).

Safety chains MUST be attached to vehicle when towing unit.

NEVER allow anyone to ride on the unit.

NEVER transport cargo on the log splitter. Check local, state and federal laws before towing. Any modifications required to meet these laws are the responsibility of the purchaser.

ALWAYS stop engine, lock beam in horizontal position and close fuel shut-off valve when transporting unit.

Keep unit free of leaves and other debris. DO NOT spray water to clean unit.

ALWAYS keep protective structures, guards, and panels in good repair, in place and securely fastened. NEVER modify or remove safety devices.

Stop and inspect equipment if there is an unusual vibration. Repair, if necessary, before restarting. Never make adjustments or repairs without first disconnecting the spark plug wire.

Keep all hardware properly tightened.

Maintain or replace safety and instruction labels, as necessary.

Use only attachments or accessories designed for your unit.

Check attachment components frequently. If worn or damaged, replace with manufacturer's recommended parts.

This product is equipped with an internal combustion engine. DO NOT use on or near any unimproved, forest covered or brush covered land unless the exhaust system is equipped with a spark arrester meeting applicable local, state or federal laws. A spark arrester, if used, must be maintained in effective working order by the operator.

DO NOT run engine in an enclosed area. Always provide good ventilation. Fumes from engine exhaust can cause injury or death.

Fuel is highly flammable and its vapors are explosive. Handle with care. Use an approved fuel container.

No smoking, No sparks, No flames. ALWAYS allow engine to cool before servicing.

NEVER fill fuel tank when engine is running or hot from operation.

NEVER fill or drain fuel tank indoors.

Replace fuel cap securely and clean up spilled fuel.

Never fill fuel containers inside a vehicle or on a truck or trailer bed with a plastic liner. Always place containers on the ground away from your vehicle before filling.

Keep the nozzle in contact with the rim of the fuel tank or container opening at all times until fueling is complete. Do not use a nozzle lock-open device.

If fuel is spilled on clothing, change clothing immediately.

NEVER store fuel inside where there is an open flame, such as a water heater.

HYDRAULIC FLUID can result in severe burns. Fluid in hydraulic system can penetrate skin and result in serious injury or death.

- Be sure to stop the engine and relieve hydraulic pressure before doing any work on hydraulic parts.

- Keep body and hands away from pin holes or nozzles which expel hydraulic fluid when under pressure. Use paper or cardboard, not hands, to search for leaks.
- Ensure all hydraulic fluid connections are tight and all hydraulic hoses and lines are in good condition before applying pressure to system.
- FOREIGN FLUID INJECTED INTO BODY can result in gangrene. Fluid must be surgically removed within a few hours by a doctor familiar with this form of injury.
- Do not adjust the pressure settings on the hydraulic pump or valve.

ALWAYS maintain unit in safe operating condition. Damaged or worn out muffler can cause fire or explosion.

Disconnect unit from tow vehicle before using.

Use wheel chocks to prevent movement of unit during operation.

Logs should be cut with square ends before placing on splitter.

When placing logs on unit position hands on sides (bark side) of logs and not on the ends. Never place hands or any part of the body between a log and any part of the log splitter.

Do not attempt to stabilize logs with legs or feet while operating. Moving parts can cut off or crush body parts.

Do not split more than one log at a time unless the cylinder has been fully extended and a second log is needed to complete the separation of the first log.

Position logs against end plate grips before operating hydraulic cylinder.

Split logs end to end in the direction of the grain, not against the grain.

Keep fingers and hands away from cracks in logs while splitting. These can quickly close and pinch or crush body parts.

On logs that are not square place the longest portion of the log closest to the beam and the most square end against the splitter wedge.

Use only your hand to operate the control lever.

ASSEMBLY



WARNING: AVOID INJURY.
Read and understand the entire Safety section before proceeding.

- Two 3/4" wrenches or sockets.
- Thin-nosed pliers.

Unpack Unit

Remove unit and all other components from the shipping container and move onto a level surface.

Tools Required:

Assemble Tongue Assembly



CAUTION: DO NOT start engine until all assembly steps have been completed.

1. Ensure that jack stand is in down position and lynch pin is installed.
2. Remove rear hex bolt and nut from frame and retain (see figure 4).
3. Remove front hex bolt and nut retaining tongue assembly to frame and retain.

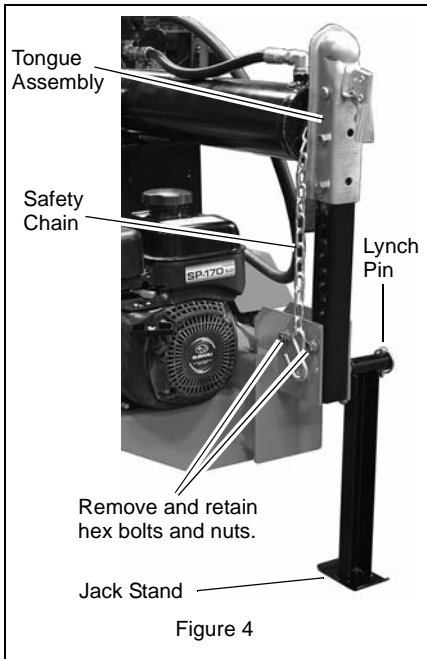

4. Position tongue assembly in operating position on frame.
5. Insert hex bolts through tongue assembly and frame (see figure 5).
6. Secure hex bolts with hex nuts.
7. Tighten all hardware.

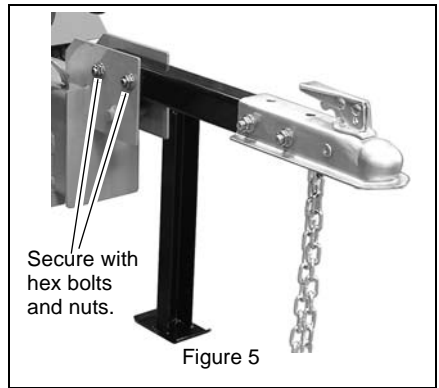

Figure 5

Attach Control Lever

(Figure 6)

1. Remove the clevis pin (1) and cotter pin (2) from the control valve.
2. Rotate the control lever up and reinsert the clevis pin.
3. Insert cotter pin back into clevis pin and spread tangs outward.

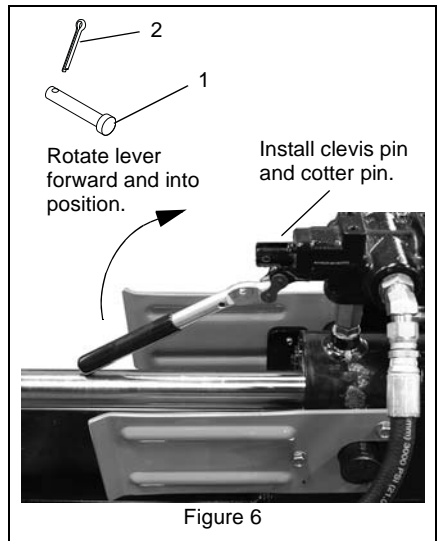

Figure 6

Check Tire Pressure



CAUTION: Avoid injury!
Explosive separation of tire and rim parts is possible when they are serviced incorrectly:

- Do not attempt to mount a tire without the proper equipment and experience to perform the job.
- Do not inflate the tires above the recommended pressure.
- Do not weld or heat a wheel and tire assembly. Heat can cause an increase in air pressure resulting in an explosion. Welding can structurally weaken or deform the wheel.
- Do not stand in front or over the tire assembly when inflating. Use a clip-on chuck and extension hose long enough to allow you to stand to one side.

See *SPECIFICATIONS* on page 20 for tire pressure.

Purge Hydraulic System

Before first use or after hydraulic system maintenance purge any air in the system by cycling the hydraulic cylinder (see *Purge Air From Hydraulic System* on page 17).

IMPORTANT: Unit shipped with partially filled hydraulic oil reservoir. Add ISO32 hydraulic oil to operating level before use.

Fill Engine Fuel Tank

Refer to Engine Manual for proper fuel type and tank capacity (see *Add Fuel to Fuel Tank* on page 14).

Check function of all controls

See *OPERATION* on page 11.

CONTROLS AND FEATURES

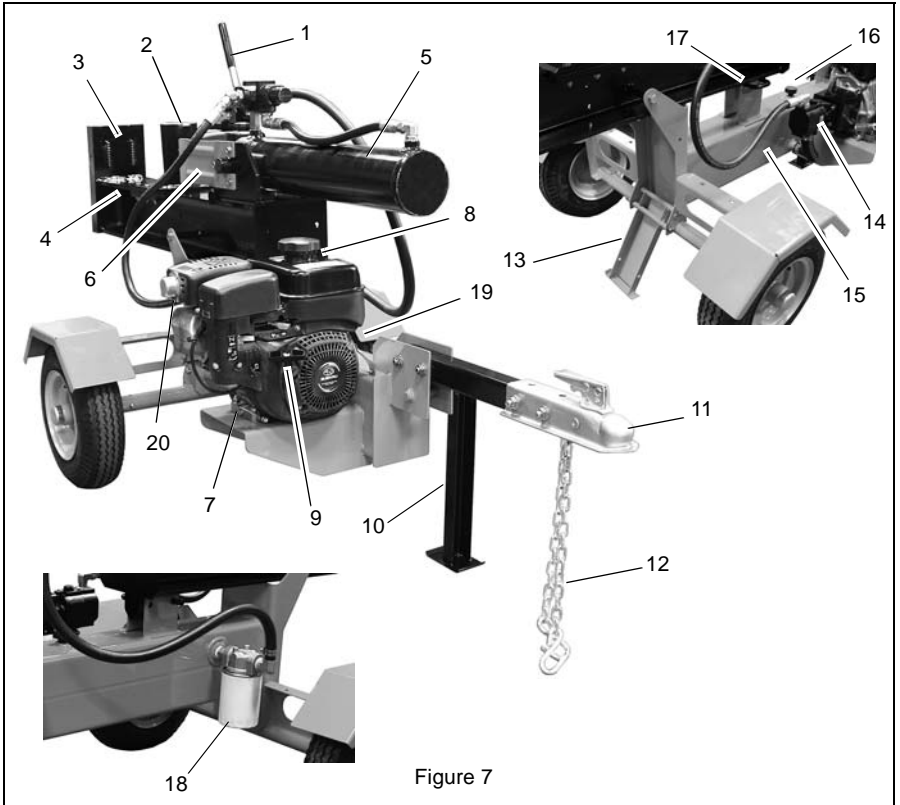

Figure 7

1. Control Lever
2. Splitter Wedge
3. End Plate/Grip
4. Beam
5. Hydraulic Cylinder
6. Stripper Plate
7. Oil Drain Plug
8. Fuel Tank/Filler
9. Recoil Starter
10. Front Jack Stand
11. Hitch Coupler – 2-In. Ball
12. Safety Chains
13. Rear Stabilizer
14. Hydraulic Pump
15. Hydraulic Tank
16. Hydraulic Tank Dipstick/Breather
17. Beam Assembly Lock
18. Hydraulic Oil Filter
19. Engine Switch
20. Muffler

OPERATION

CONTROLS AND FEATURES



WARNING: AVOID INJURY.
Read and understand the entire
Safety section before proceeding.

See figure 7 for all controls and features locations.

Engine Switch

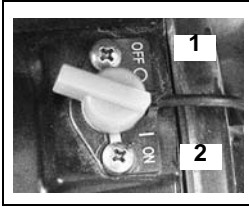

The engine switch has two positions:

1. OFF – Engine will not start or run.
2. ON – Engine will start and run.

Choke Control Lever

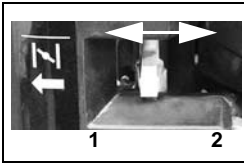

1. Choke Closed position: chokes off air to engine for easier start.
2. Choke Open position: allows for normal operation.

IMPORTANT: Gradually open choke after engine starts.

Throttle Control Lever

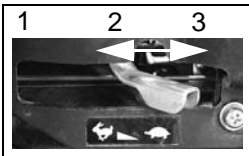

The throttle controls the engine speed. To increase or decrease the engine speed, adjust to:

1. Fast (normal or warm starts)
2. Part-Throttle
3. Slow (cold weather starts)

Fuel Shut-Off Valve

IMPORTANT: The fuel shut-off valve **MUST** be in the closed position prior to transporting the unit.

The fuel shut-off valve has two positions:



Closed Position:
Use this position to service, transport, or store the unit.



Open Position:
Use this position to run the unit.

Figure 8

Recoil Starter Handle

When pulled, handle will turn engine over.

IMPORTANT: DO NOT let handle snap back against starter.

Control Lever (Figure 9)

The control lever is used to move the splitting wedge in or out when operating in the horizontal position or up and down when operating in the vertical position.

Horizontal Operating Position

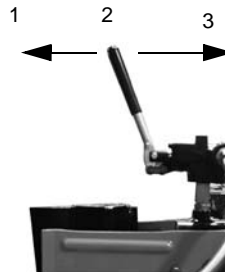

Vertical Operating Position

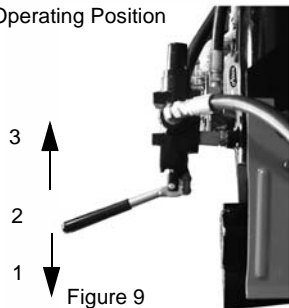

Figure 9

Out/Down (1) – Move lever in this direction to extend cylinder toward end plate. Keep pressure on lever until log is split. Lever does not lock in this position. Release as soon as log is split or cylinder is fully extended.

NOTE: Splitter wedge is designed to reach full extension and stop between 1 and 2" (25 and 50 mm) before contacting end plate.

IMPORTANT: When cylinder is fully extended do not hold lever in out position. Pump damage will result.

Neutral (2) – In this position the cylinder does not move even though the engine is running.

Return/Up (3) – Move lever in this direction to retract cylinder. Push lever fully in this direction to lock in return mode. Lever will automatically return to neutral once cylinder fully retracts.



WARNING: Keep hands and fingers away from splitter wedge and stripper plates during cylinder retraction.

Beam Lock

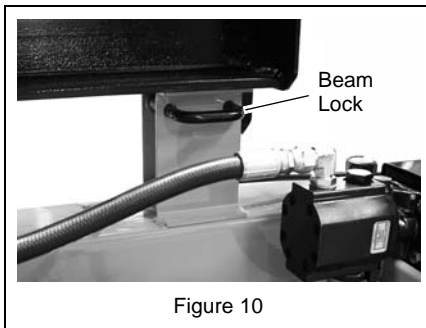

Figure 10

Locks the beam in the horizontal operating position. To move beam to vertical operating position:

1. Pull beam lock out until the pin clears the mount (Figure 10).
2. Rotate beam lock slightly so pin does not return to hole in mount.
3. Lift beam until it rotates to vertical position (Figure 11).



CAUTION: Beam assembly is heavy. Use care when moving between vertical and horizontal positions.

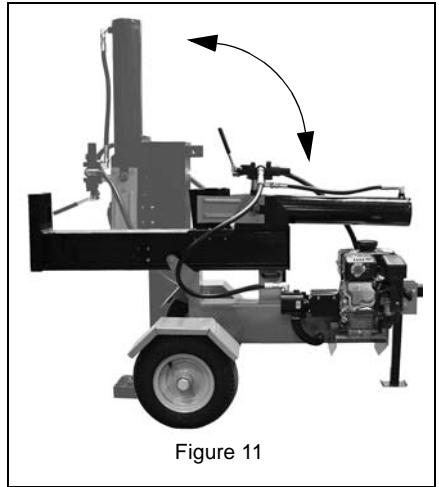

Figure 11

IMPORTANT: Rear stabilizer must be in the transport position before placing beam in vertical operating position (see *Rear Stabilizer* on page 13).

To move beam to horizontal position:

1. Carefully rotate beam down until seated on lock bracket.
2. Turn beam lock until pin lines up with hole in lock bracket and release (Figure 10).
3. Ensure that beam lock pin fully engages in bracket.

Stripper Plates

(Figure 12)

The stripper plates are designed to remove a log that has partially split but remains stuck on the wedge.

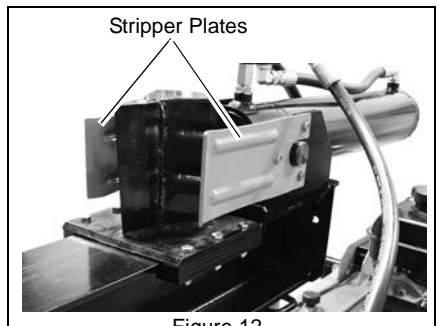

Figure 12

To remove stuck logs from the splitter wedge:

1. Move the control lever to the Return/Up position.
2. Allow the cylinder to retract until the stuck log contacts the stripper plates.

3. Continue to retract the cylinder until the log is dislodged from the splitter wedge.
4. Once removed from the splitter wedge rotate log and split from a different location or split log from the other end.



CAUTION: Do not use the unit if the stripper plates are bent or damaged. Bent or damaged stripper plates must be repaired or replaced before use.

Front Jack Stand

(Figure 13)

Front jack stand must be locked in the down position whenever the unit is in use.

1. Remove lynch pin from assembly.
2. Rotate jack stand down until holes in jack stand align with holes in mount.
3. Insert lynch pin all the way through jack stand and mount.



CAUTION: Jack stand must be locked in the transport position before towing the unit.

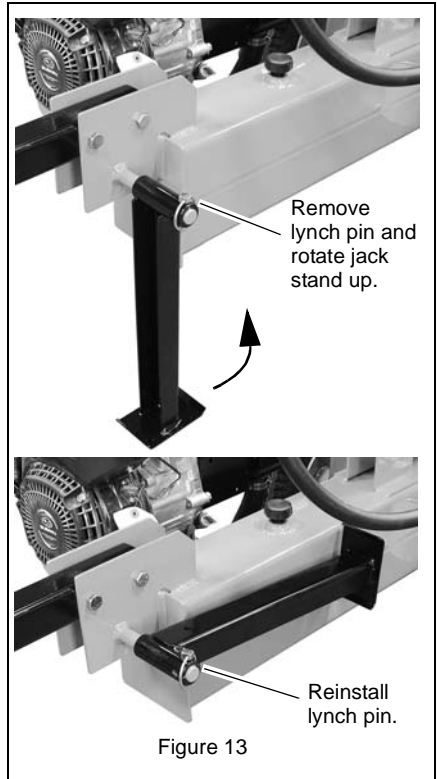

Figure 13

Rear Stabilizer

(Figure 14)

Rear stabilizer must be positioned down and locked in place when operating in the horizontal position.

1. Remove hair pin from upper lock pin and slide lock pin out from brackets.
2. Rotate rear stabilizer down until holes in stabilizer align with holes in brackets.
3. Insert lock pin all the way through brackets and stabilizer.
4. Reinstall hair pin.

IMPORTANT: Rear stabilizer must be locked in the transport position before towing unit or before placing beam in vertical operating position.

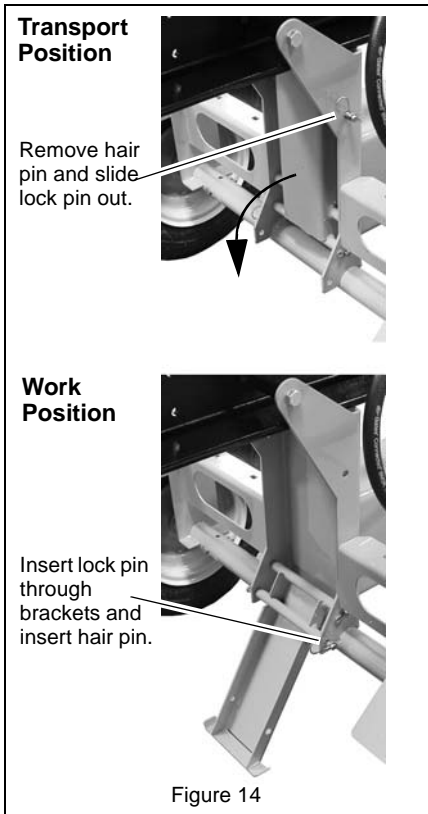

OPERATION

Add Fuel to Fuel Tank

1. ALWAYS place unit in open or well-ventilated area.
2. Stop engine and allow to cool.
3. Clean fuel cap and surrounding area to prevent dirt from entering fuel tank.
4. Remove cap.

IMPORTANT: DO NOT use gasohol or gasoline containing alcohol. See Engine Manual for correct type and grade of fuel.

5. Fill fuel tank to within 1/2 in. (1.2 cm) of bottom of filler neck with unleaded gasoline.

NOTE: Tank capacity is .9 gallon (3.4 liters).

6. Replace fuel cap and tighten.
7. ALWAYS clean up any spilled fuel.

Start Engine

1. Make sure control lever is in neutral position.
2. Move the engine switch to the ON position.
3. Open the fuel shut off valve.

4. Set the choke lever based on engine temperature (see *Choke Control Lever* on page 11).
5. Slowly pull the recoil starter until engine compression makes pulling difficult. Let the starter rewind a little, and then pull smoothly and quickly to start the engine.
6. Repeat step 5 as needed.
7. Fully open the choke and set the throttle to full fast before operating the unit.

Stop Engine

1. Return cylinder to fully retracted position.
2. Move throttle lever to slow position.
3. Move the engine switch to the OFF.
4. Close the fuel shut-off valve.

TRANSPORTING UNIT

IMPORTANT: Check local, state and federal laws before towing unit. Any modifications required to meet these laws are the responsibility of the purchaser.



CAUTION: Unit can cause serious injury if it rolls out of control or tips over. Chock wheels when unit is not attached to a tow vehicle.

Ensure that wheel bearings are well packed with grease and that tires are inflated properly before towing. To tow unit:

1. Place beam in horizontal position and engage beam lock (see *Beam Lock* on page 12).
2. Move fuel shut-off valve to closed position.
3. Move rear stabilizer to transport position and lock in place (see *Rear Stabilizer* on page 13).
4. Attach log splitter hitch to tow vehicle with class 1 or higher receiver and 2-in. ball. Adjust hitch coupler to ensure lock lever fully locks onto ball with no excess movement. Install a locking pin or lock through the lock lever.
5. Move front jack stand to transport position and lock in place (see *Front Jack Stand* on page 13)

NOTE: Tow vehicles with low ball heights will require the jack stand to be stored before attaching the hitch coupler to the ball.

6. Cross unit safety chains under the coupler and attach to tow vehicle.



CAUTION: Avoid damage or injury! Use maximum caution when towing log splitter:

- DO NOT exceed 45 mph (72.4 kph).
- Obey all applicable local, state and federal laws regarding towing.
- DO NOT carry passengers, cargo or logs on the towed unit.
- Allow for the extra length of the unit when turning, parking, crossing intersections and in all driving situations.
- Ensure that stabilizers are locked in the transport position and that the beam is locked before moving unit.
- Drive slowly and take extra caution over rough terrain.

OPERATION

Work Site

Set up log splitter in an area that provides:

- a dry level surface.
- good footing that is free of debris or other tripping hazards.
- sufficient clearance for engine exhaust to not blow directly on combustible material.

Disconnect the log splitter from the tow vehicle before operating. If splitting logs in the horizontal position, move rear stabilizer to work position (see *Rear Stabilizer* on page 13). Chock the wheels to prevent movement during operation.

Warm Up Unit

When using the unit in temperatures of 68° F (20° C) or lower, the hydraulic system should be cycled before splitting logs. This allows the cool hydraulic oil in the cylinder to be circulated before placing a load on the hydraulic system.

1. Start the engine and allow it warm up (see *Start Engine* on page 14).
2. Cycle the cylinder through three or four full extension/retraction cycles.
3. Proceed with splitting logs.

IMPORTANT: Always split logs with engine set at Fast position.

Splitting Logs



WARNING: AVOID INJURY. Read and understand the entire *Safety* section before proceeding.

Determine if the size of the logs to be split can be safely and comfortably lifted up onto the beam in the horizontal position. If logs are too heavy for the operator, position the beam in the vertical position for splitting.



CAUTION: During operation, engine and hydraulic system are hot. Always stop engine and allow unit to cool before changing beam positions.

Working only in the Operator Zone (see *OPERATOR ZONE* on page 5):

1. Fully retract cylinder.
2. Place log on beam:
 - Split only from log ends, with the grain.
 - Position log against grips on end plate with the squarest end toward the splitter edge.
 - Position hands on sides of logs when placing logs on unit and not on the end. Never place hands or any part of the body between a log and any part of the log splitter.
 - Do not attempt to stabilize logs with legs or feet while operating.
3. Using only your hand, push the control lever toward the log.
4. Hold the lever in the out position until log is split.
5. Allow split logs to drop to the ground. DO NOT try to catch split logs.
6. Move control lever away from the log until it locks into retract position. Lever will automatically return to neutral once cylinder is fully retracted.
7. Do not load another log or remove split pieces until the cylinder has completely stopped and the control lever is in the neutral position. Do not reach across the unit.
8. Split only one log at a time unless the cylinder has been fully extended and a second log is needed to complete the separation of the first log.
9. Move split logs as necessary to ensure that all tripping hazards have been eliminated from the operator zone.

FOR BEST PERFORMANCE

- Ensure that logs to be split are cut as square as possible.

- Split dry, cured logs. Wet or recently cut logs will be more difficult to split.
- Split logs with straight grain. Logs with knots or twisted or irregular grain patterns will be more difficult to split.
- Move split logs as needed to keep operator zone free of tripping hazards.
- When splitting logs that are not square place the longest portion of the log closest to the beam and the most square end against the splitter wedge.

MAINTENANCE SCHEDULE



WARNING: AVOID INJURY. Read and understand the entire *Safety* section before proceeding.

IMPORTANT: Proper maintenance can prolong the life of unit. The following chart shows the recommended service schedule.

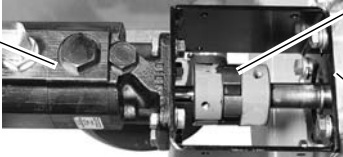
Interval	Task	Action
Each Use	Clean Unit	Clean engine and hydraulic tank of all dirt and debris. DO NOT spray unit with water. Do not use solvents, hard cleaners, or abrasives. NOTE: Protect painted surfaces with automotive-type wax.
	Check Tires	See <i>SPECIFICATIONS</i> on page 20 for correct tire pressure. See <i>Check Tire Pressure</i> on page 9.
	Check Engine Oil	Refer to engine manual.
	Check Hydraulic Oil Level	See <i>Checking Hydraulic Oil Level</i> on page 17.
	Check Hydraulic Lines	Check for leaking, kinked or damaged lines. Replace as necessary. See <i>HYDRAULIC OIL SYSTEM</i> on page 17.
	Follow Engine Maintenance Schedule	Perform scheduled engine maintenance. Refer to Engine Manual for detailed instructions.
50 Hours or Every Season	Check Fasteners	Check all fasteners. Replace fasteners that are missing or damaged. Tighten all nuts and bolts to the correct torque value.
100 Hours or Every Season	Change Hydraulic Oil and Filter	Drain oil from hydraulic tank, replace filter and refill tank with ISO 32 hydraulic oil. See <i>Changing Hydraulic Oil and Filter</i> on page 17.
	Check Hydraulic Drive Coupling	Inspect hydraulic drive coupling for damage or deterioration. Replace as necessary. <div style="display: flex; align-items: center; justify-content: center;"> <div style="margin-right: 10px;">Hydraulic Pump</div>  <div style="margin-left: 10px;">Drive Coupling</div> </div> <div style="margin-left: 100px; margin-top: 5px;">Engine</div>
	Check Wheel Bearings	Remove bearing dust caps and inspect and repack wheel bearings with grease. After packing bearings seat bearings by tightening the spindle nut snug. Loosen nut, spin wheel and retighten slightly until first slot in castle nut aligns with hole in hub. Replace cotter pin and dust cap. Wheel should spin freely with no wobble.

HYDRAULIC OIL SYSTEM



WARNING: HYDRAULIC FLUID can result in severe burns. Fluid in hydraulic system can penetrate skin and result in serious injury or death.

Be sure to stop the engine and relieve hydraulic pressure before doing any work on hydraulic parts.

Keep body and hands away from pin holes or nozzles which expel hydraulic fluid when under pressure. Use paper or cardboard, not hands, to search for leaks.

Ensure all hydraulic fluid connections are tight and all hydraulic hoses and lines are in good condition before applying pressure to system.

FOREIGN FLUID INJECTED INTO BODY can result in gangrene. Fluid must be surgically removed within a few hours by a doctor familiar with this form of injury.

Checking Hydraulic Oil Level

1. Start the unit and run it to operating temperature (about 10 minutes).
2. Cycle the hydraulic cylinder in and out two or three times.
3. Shut off engine.
4. Remove any dirt that may be around the cap/breather on the hydraulic reservoir.
5. Remove cap/breather and check oil level. Oil should be near the top of the dipstick.

IMPORTANT: Unit shipped with partially filled hydraulic oil reservoir. Add ISO32 hydraulic oil to operating level before use.

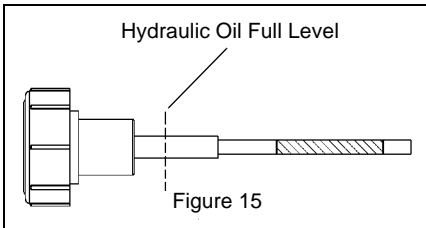

6. Add ISO Grade 32 hydraulic oil (Ariens p/n 00069100) as necessary. Do not overfill.

Changing Hydraulic Oil and Filter

NOTE: Change the hydraulic oil and oil filter every season or 100 hours. Use ISO Grade 32 hydraulic oil (Ariens p/n 00069100).

1. Clean area around hydraulic supply hose.
2. Place container under oil filter and hydraulic supply hose to catch oil.
3. Remove hose clamp and disconnect hose from hydraulic tank. See figure 16.

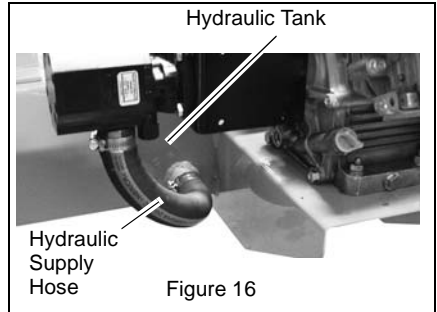

4. Remove oil filter.
5. Allow tank to drain.
6. Reinstall hydraulic suction hose and tighten hose clamp.
7. Lubricate rubber gasket on new oil filter with clean hydraulic oil.
8. Spin new oil filter onto filter housing until it makes contact. Tighten oil filter another 1/2 turn.
9. Add new oil to the oil tank.
10. Check hydraulic oil level.
11. Properly dispose of waste oil.

Purge Air From Hydraulic System

1. With the engine running, extend the hydraulic cylinder out fully and then retract fully.
2. Repeat 4 – 5 times. Erratic movement in the hydraulic cylinder indicates that there is air in the system.
3. Stop the engine and check the hydraulic oil level. Add if necessary.
4. Repeat extending and retracting of hydraulic cylinder unit motion is consistent and smooth in both directions.
5. Ensure that hydraulic oil is at proper level.

STORAGE

SHORT TERM

NEVER spray unit with high pressure water or store unit outdoors.

Inspect unit for visible signs of wear, breakage or damage.

Keep all nuts, bolts and screws properly tightened and know unit is in safe working condition.

Store unit in a cool, dry protected area.

Protect bare-metal areas with a light coat of oil or anti-rust compound.

LONG TERM

Perform all steps found in Short Term storage.

Touch up all scratched painted surfaces.

Remove weight from wheels by putting blocks under frame or axle.

Fuel System

Gasoline left in the fuel system for extended periods without a stabilizer will deteriorate, resulting in gum deposits in the system. These deposits can damage the carburetor and the fuel hoses, filter and tank. Prevent deposits from forming in the fuel system during storage by adding a quality fuel stabilizer to the fuel. Follow the recommended mix ratio found on the fuel stabilizer container.

To treat the fuel system for storage:

1. Add fuel stabilizer (Ariens part number 00592900) according to manufacturers's instructions.
2. Run engine for at least 10 minutes after adding stabilizer to allow it to reach the carburetor.

NEVER store the engine with fuel in the fuel tank inside of a building with potential sources of ignition.

To Take the Unit Out of Storage

1. Refer to the engine service manual to prepare the engine for service.
2. Put fresh, clean fuel in the fuel tank.
3. Begin the maintenance schedule.

TROUBLESHOOTING

PROBLEM	PROBABLE CAUSE	CORRECTION
Engine will not start.	<ol style="list-style-type: none"> 1. Engine switch in Off position. 2. Fuel shut-off valve in Off position. 3. Fuel tank empty. 4. Spark plug disconnected. 5. Faulty spark plug. 6. Choke lever in wrong position. 7. Faulty engine. 	<ol style="list-style-type: none"> 1. Move switch to On position (see <i>Engine Switch</i> on page 11). 2. Move valve to On position (see <i>Fuel Shut-Off Valve</i> on page 11). 3. Fill fuel tank with fuel (see <i>Fill Engine Fuel Tank</i> on page 9). 4. Connect spark plug. 5. Replace spark plug. 6. Adjust choke lever position (see <i>Choke Control Lever</i> on page 11). 7. See your Ariens Dealer.
Engine overheats.	<ol style="list-style-type: none"> 1. Debris accumulated on engine and cooling fins. 	<ol style="list-style-type: none"> 1. Clean debris from engine and cooling fins.
Cylinder does not extend or retract when control lever is moved.	<ol style="list-style-type: none"> 1. Low hydraulic oil level. 2. Kinked or pinched hydraulic lines. 3. Hydraulic drive coupling broken. 4. Faulty hydraulic pump. 5. Faulty control valve. 	<ol style="list-style-type: none"> 1. Refill hydraulic oil to proper level (see <i>Checking Hydraulic Oil Level</i> on page 17). 2. Repair or replace damaged hydraulic lines. 3. Replace hydraulic drive coupling (see <i>MAINTENANCE SCHEDULE</i> on page 16). 4. See your Ariens Dealer. 5. See your Ariens Dealer.
Excessive vibration or noise from hydraulic drive coupling.	<ol style="list-style-type: none"> 1. Worn or damaged drive coupling. 	<ol style="list-style-type: none"> 1. Replace hydraulic drive coupling (see <i>MAINTENANCE SCHEDULE</i> on page 16)
Erratic movement of cylinder.	<ol style="list-style-type: none"> 1. Air in hydraulic system. 	<ol style="list-style-type: none"> 1. Purge air from hydraulic system (see <i>Purge Air From Hydraulic System</i> on page 17).
Control lever sticks.	<ol style="list-style-type: none"> 1. Debris in control lever linkage. 2. Dented rear cap on control lever valve assembly. 	<ol style="list-style-type: none"> 1. Clean and lubricate linkage. 2. See your Ariens Dealer.

SERVICE PARTS

See your authorized Ariens dealer for genuine OEM service parts.

Part No.	Qty	Description
03835951	1	Wedge, Splitter
09414200	1	Hydraulic Oil Filter
20020002	1	Air Filter
20020001	1	Spark Plug
00069100	AR	Hydraulic Oil – ISO 32

ACCESSORIES

See your authorized Ariens dealer to add these optional accessories to your unit.

Part No.	Description
71701600	Log Cradle Kit
71701300	Light Kit
71701400	License Plate Light Holder
00592900	Fuel Stabilizer 4 oz.

SPECIFICATIONS

Model Number	917001
Model	27-Ton Log Splitter
Engine	
Engine	Subaru
Engine Model Number	SP170 – CARB
Displacement – Cu. In. (cc)	10.31 (169)
Max RPM	3800±100
Oil Capacity – Pt. (L)	1.3 (.6)
Fuel Tank Capacity Qt. (L)	3.6 (3.4)
Fuel Octane Rating	Refer to Engine Manual
Hydraulic System Capacity – Gal. (L)	4.5 (17)
Splitting Force – Ton (kg)	27 (24,494)
Cylinder Cycle Time – Seconds	17
Bed Capacity: Log Length – in. (cm)	25 (63.5)
Size and Weight	
Length: Horizontal Position – in. (cm)	86.25 (219)
Length: Vertical Position – in. (cm)	83.75 (212.7)
Width – in. (cm)	38.25 (97.2)
Height: Horizontal Position – in. (cm)	46.50 (118.1)
Height: Vertical Position – in. (cm)	64.75 (164.5)
Weight – lbs. (kg)	500 (226.8)
Tires	
Tire Size – in.	4.80/4.00 x 8
Tire Pressure – psi (kPa)	30 (137.9)
Maximum Towing Speed – mph (kph)	45 (72.4)
Hitch Coupler – in. (cm)	2 (5.1)



Two-Year Limited Lawn and Garden Walk Behind Warranty

This warranty statement applies only to 21-Inch Walk Behind Lawn Mowers, Wide Area Walks, Super Striper Mowers, Tillers, String Trimmers, Log Splitters, Edgers and Power Brushes

Ariens Company (Ariens) warrants to the **original purchaser** that Ariens and Gravely brand consumer products manufactured and sold by Ariens after December 31, 2007 will be free from defects in material and workmanship for a period of two years after the date of purchase. An authorized Ariens dealer (Ariens brand products) or Gravely dealer (Gravely brand products) will repair any defect in material or workmanship, and repair or replace any defective part, subject to the conditions, limitations and exclusions set forth herein. Such repair or replacement will be free of charge (labor and parts) to the original purchaser except as noted below.

One-Year Limited Warranty on Professional/Commercial 21-inch Walk-Behind Lawn Mowers

21-inch walk-behind lawn mowers labeled or designated by Ariens as a Professional/Commercial product put to any business use, agricultural, commercial, or industrial, are warranted to the **original purchaser** to be free from defects in material and workmanship for a period of one year after the date of purchase.

90-Day Limited Warranty on Service Parts and Accessories

Genuine Ariens or Gravely brand service parts and accessories are warranted to be free from defects in material and workmanship for a period of 90 days after the date of purchase. An authorized Ariens or Gravely dealer will repair or replace any such part or accessory free of charge, except for labor, during that period.

Except for 21-inch walk-behind lawn mowers labeled or designated by Ariens as a Professional/Commercial product, the duration of all warranties herein applies only if the product is put to personal use around a household or residence. If the product is put to any business use, agricultural, commercial, or industrial, then the duration of these warranties shall be 90 days after the date of purchase. If any product is rented or leased, then the duration of these warranties shall be 90 days after the date of purchase.

Exceptions, Limitations, Exclusions

Customer Responsibilities

Register the product immediately at the time of sale. If the dealer does not register the product, the customer must complete the product registration card in the literature package and return it to the Ariens Company, or register the unit online at www.ariens.com or www.gravely.com.

To obtain warranty service, the **original purchaser** must:

- Perform the maintenance and minor adjustments explained in the owner's manual.
- Promptly notify Ariens or an authorized Ariens or Gravely service representative of the need for warranty service.
- Transport the product to and from the place of warranty service.
- Have the warranty service performed by an authorized Ariens or Gravely service representative.

To find an Ariens or Gravely authorized service representative, contact Ariens at:

655 W. Ryan Street
Brillion, WI 54110
(920) 756 - 2141
www.ariens.com
www.gravely.com

Exceptions and Limitations

- Batteries are warranted only for a period of 12 months after date of purchase, on a prorated basis. For the first 90 days of the warranty period, a defective battery will be replaced free of charge. If the applicable warranty period is more than 90 days, Ariens will cover the prorated cost of any defective battery, for up to 12 months after the date of purchase.

Exclusions – Items Not Covered by This Warranty

- Engines and engine accessories are covered only by the engine manufacturer's warranty and are not covered by this warranty.
- Parts that are not genuine Ariens or Gravely service parts are not covered by this warranty.
- The following maintenance, service and replacement items are not covered by this warranty unless they are noted in the Limitations section above: lubricants, spark plugs, oil, oil filters, air filters, fuel filters, brake linings, brake arms, shoes, runners, scraper blades, shear bolts, mower blades, mower vanes, tines, brushes, headlights, light bulbs, knives, cutters.
- Any misuse, alteration, improper assembly, improper adjustment, neglect, or accident which requires repair is not covered by this warranty.
- This warranty applies only to products purchased in the United States (including Puerto Rico) and Canada. In all other countries, contact place of purchase for warranty information.

Disclaimer

Ariens may from time to time change the design of its products. Nothing contained in this warranty shall be construed as obligating Ariens to incorporate such design changes into previously manufactured products, nor shall such changes be construed as an admission that previous designs were defective.

LIMITATION OF REMEDY AND DAMAGES

Ariens Company's liability under this warranty, and under any implied warranty that may exist, is limited to repair of any defect in workmanship, and repair or replacement of any defective part. Ariens shall not be liable for incidental, special, or consequential damages (including lost profits). Some states do not allow the exclusion of incidental or consequential damages, so the above limitation or exclusion may not apply to you.

DISCLAIMER OF FURTHER WARRANTY

Ariens Company makes no warranty, express or implied, other than what is expressly made in this warranty. If the law of your state provides that an implied warranty of merchantability, or an implied warranty of fitness for particular purpose, or any other implied warranty, applies to Ariens Company, then any such implied warranty is limited to the duration of this warranty. Some states do not allow limitations on how long an implied warranty lasts, so the above limitation may not apply to you.

This warranty gives you specific legal rights, and you may also have other rights which vary from state to state.



Ariens Company
655 West Ryan Street
Brillion, WI 54110-1072
920-756-2141
Fax 920-756-2407
www.ariens.com



WARNING



The engine exhaust from this product contains chemicals known to the State of California to cause cancer, birth defects or other reproductive harm.